

Request to Verify DFM2800 Torque Motor Model

Applicable machines

This notification is for customers who own DFM2800 machines manufactured between February 2014 and March 2018.



Please verify the torque motor model

There are 2 types of torque motor installed in 3 locations inside the DFM2800, but we have found that some machines with torque motors installed in the wrong locations were shipped.

If a torque motor is wrong, there are cases where the motor's temperature will increase to approximately 100°C. Since there is a risk of burns, please verify the torque motor model after confirming that the torque motor temperature is 40°C or less.

Torque motor installation positions and models (→See the following pages for the detailed procedures.)

The correct model for each torque motor is as shown below. They are all for the unwinder.

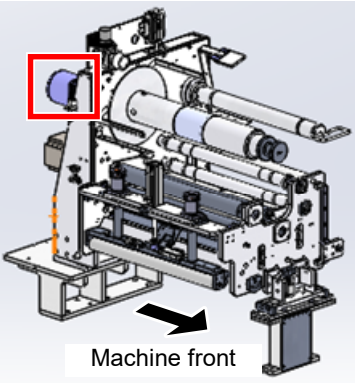
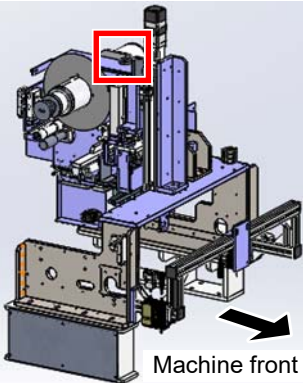
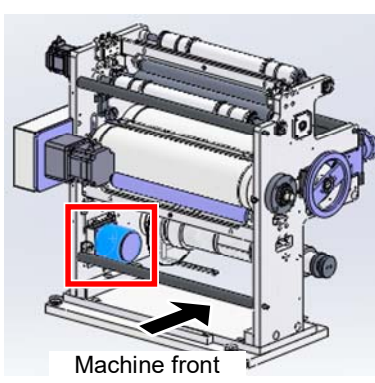
	Dicing tape feeding unit	BG tape peeling unit	Batch-cutting unit [optional accessory]
Installation position			
Model	4TK10GN-CW2J	4TK10GN-AW2J	4TK10GN-CW2J

If the wrong torque motor is installed

We will replace it, so please contact DISCO.

Even if a torque motor is wrong, since it is protected with a thermal guard (the motor stops at 130°C), there is no risk of a fire starting. In addition, we have verified based on tests that there is no impact on processing operations.

Procedures to verify the torque motor model



Perform this operation after shutting OFF the machine's power and the facility power being supplied to the machine

This operation is performed by putting your hands into the drive section. If it is performed without shutting OFF the machine power, there is a risk of your fingers or hands being caught or amputated.

During the operation, do not allow anybody else except the maintenance personnel to touch the machine

This procedure requires the maintenance personnel to put their hands into the drive section, where their fingers or hands could be caught or cut off. If a person other than the personnel touches the machine, it may operate unexpectedly, causing the personnel to get injured.

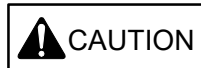

Perform this operation after turning OFF the machine's power and confirming that the torque motor's temperature is 40°C or less

There are cases where the torque motor temperature increases to approximately 100°C. There is a risk of burns if you touch the hot motor.

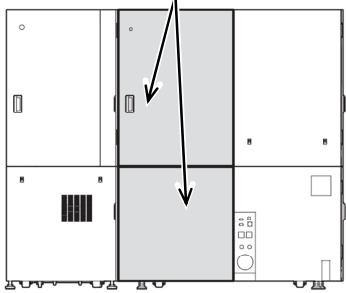
Step No.	Procedure
1	Initialize the machine.
2	Turn OFF the machine.
3	Turn the power circuit breaker lever at the rear side of the machine to the "OFF" position and lockout the lever with a padlock or the like.
4	Shut OFF the facility-side power.
5	Close the air valve at the facility side.
6	Open the doors at the rear side of the machine. <div style="text-align: center;"> <p>Open the doors.</p>  <p>Rear side</p> </div>

Procedures to verify the torque motor model (Continued)

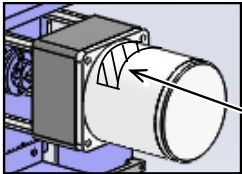
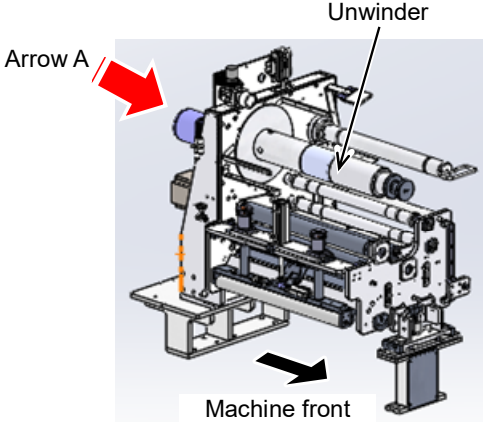
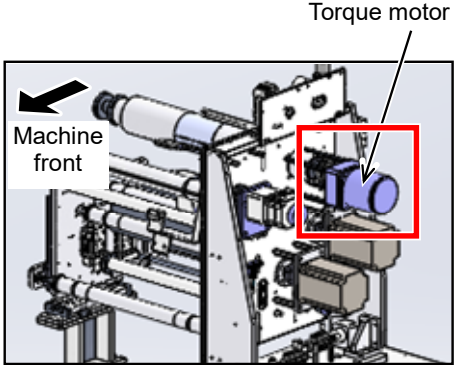
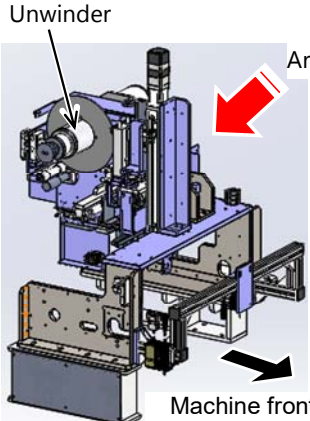
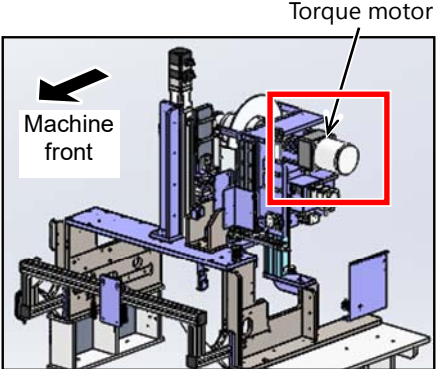
Step No.	Procedure
7	<p>Using a thermometer, <u>confirm that the temperature of each torque motor is 40°C or less.</u></p> <ul style="list-style-type: none"> The model of each torque motor is indicated on the cylindrical section, as shown in the image below.  <p>Position where torque motor model is indicated</p> <ul style="list-style-type: none"> If the model is difficult to see, use a handheld mirror.
8	<p>Verify the model of the torque motor at the rear of the dicing tape feeding unit unwinder. Model: 4TK10GN-CW2J</p>  <p>Unwinder Machine front Dicing tape feeding unit</p>  <p>Torque motor Machine front Viewed from the arrow A</p>
9	<p>Verify the model of the torque motor at the rear of the BG tape peeling unit unwinder. Model: 4TK10GN-AW2J</p>  <p>Unwinder Machine front BG tape peeling unit</p>  <p>Torque motor Machine front Viewed from the arrow B</p>

Procedures to verify the torque motor model (Continued).

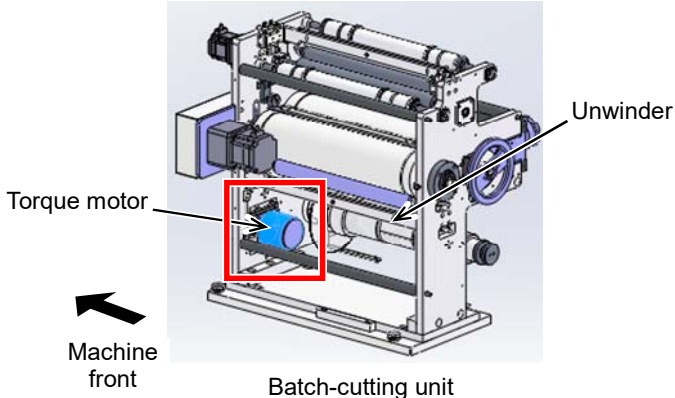
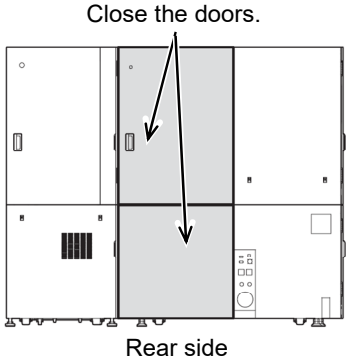
Step No.	Procedure
10	<p>Verify the model of the torque motor for the unwinder of the batch-cutting unit [optional accessory]. Model: 4TK10GN-CW2J</p> 
11	<p><u>If a torque motor is installed whose model is different from the model indicated in this document:</u> Please contact DISCO.</p> <ul style="list-style-type: none"> • Until DISCO performs replacement, do not touch the torque motor immediately after machine stopping. There is a risk of burns if you touch a hot motor.
12	<p>Close the doors at the rear side of the machine.</p> 

Inquiries

Please contact your local DISCO sales representative or DISCO customer engineer if you have any questions regarding this matter.